

Note: See page 14 for a complete description of the above part number system.

Sold & Serviced By:

 Toll Free Phone (877) SERV098
 Toll Free Fax (877) SERV099
www.electromate.com
sales@electromate.com

(E) - English Interface	(M) - Metric Interface
(LFT) - Left Facing Thread	(NPL) - Non Preloaded
(LH) - Left Hand	(PL) - Preloaded
(LT) - Low Thrust	(RFT) - Right Facing Thread
(HT) - High Thrust	(RH) - Right Hand

Screw & Nut Specifications

Model Number	Nut Type	Diameter inches (mm)	Lead inches (mm)	Root Diameter inches (mm)	Ball Diameter inches (mm)	Number of Circuits	Static Load lbs (kgf)	Dynamic Load ⁽¹⁾ lbs (kgf)
RS100025 1.000 inch dia. 0.250 inch lead	<i>Non-preloaded Ball (N1/N2)</i>	1.000 (25,40)	0.250 (6,35)	0.836 (21,23)	0.156 (3,96)	2	30,750 (13947)	3,350 (1519)
	<i>Preloaded Ball (N3/N4)</i>						30,415 (13796)	3,015 (1367)
	<i>Non-preloaded Turcite (N5/N6)</i>				n/a	n/a	1,500 (680)	195 (88)
	<i>Preloaded Turcite (N7/N8)</i>				n/a	n/a	1,500 (680)	175 (79)
RS100050 1.000 inch dia. 0.500 inch lead	<i>Non-preloaded Ball (N1/N2)</i>	1.000 (25,40)	0.500 (12,70)	0.879 (22,32)	0.156 (3,96)	2	32,300 (14650)	3,950 (1791)
	<i>Preloaded Ball (N3/N4)</i>						31,905 (14471)	3,555 (1612)
	<i>Non-preloaded Turcite (N5/N6)</i>				n/a	n/a	1,500 (680)	195 (88)
	<i>Preloaded Turcite (N7/N8)</i>				n/a	n/a	1,500 (680)	175 (79)
RS100100 1.000 inch dia. 1.000 inch lead	<i>Non-preloaded Ball (N1/N2)</i>	1.000 (25,40)	1.000 (25,40)	0.836 (21,23)	0.156 (3,96)	2	13,750 (6236)	2,250 (1020)
	<i>Preloaded Ball (N3/N4)</i>						13,525 (6134)	2,025 (918)
	<i>Non-preloaded Turcite (N5/N6)</i>				n/a	n/a	1,500 (680)	195 (88)
	<i>Preloaded Turcite (N7/N8)</i>				n/a	n/a	1,500 (680)	175 (79)

Other Specifications

Maximum Acceleration Rate	Ball nut: 772 inches/sec ² (19.6 m/sec ²) Turcite nut: 193 inches/sec ² (4.9 m/sec ²)
Maximum Speed	Ball nut: 3000 rpm Turcite nut: 1500 rpm
Screw Material Screw Extensions	Right Hand Thread, Case Hardened Rc 58 Steel Rolled Ball Screw 605 Woodruff Keyways on Extensions from Support Housings
Screw Maximum Length ⁽²⁾ Screw Weight	144 inches (3657 mm) 2.33 lbs/ft (34,7 g/cm)
Support Housings Support Housing Features	Steel with Black Oxide Finish, 45° Chamfer x .03 inch (0,76) all Straight Edges Base or Face Mount with Integral Seals
Nut Flanges Nut Flange Features	Steel with Black Oxide Finish English or Metric Load Mounting Interface

Footnotes:

Sold & Serviced By:  Page 15 of 20
⁽¹⁾ Based on 1 million inches (25 Km) of travel life. See page 51 for further travel life ratings.
⁽²⁾ Maximum stock length (not the maximum thread length with bearing housings). See page 50 for maximum thread lengths for each configuration.

Screw Specifications

Model Number	Nut Type	Screw Efficiency %	Lead Error inch/ft (mm/300 mm)	Backlash inches (mm)	Unidirectional Repeatability inches (mm)	Bidirectional Repeatability inches (mm)
RS100025 1.000 inch dia. 0.250 inch lead & RS100050 1.000 inch dia. 0.500 inch lead & RS100100 1.000 inch dia. 1.000 inch lead	<i>Non-preloaded</i> Ball (N1/N2)	90	< 0.009 (0,229)	< 0.009 (0,229)	+/- 0.0002 (0,0050)	+ 0.0002 to - 0.0092 (0,0050) (0,2300)
	<i>Preloaded</i> Ball (N3/N4)					+ 0.0002 to - 0.0002 (0,0050) (0,0050)
	<i>Non-preloaded</i> Turcite (N5/N6)	60	< 0.009 (0,229)	< 0.009 (0,229)	+/- 0.0002 (0,0050)	+ 0.0002 to - 0.0092 (0,0050) (0,2300)
	<i>Preloaded</i> Turcite (N7/N8)					+ 0.0002 to - 0.0002 (0,0050) (0,0050)

Assembly Specifications

Model Number	Nut Type	Breakaway Torque oz-in (N-m)				
		Simple-Simple	Fixed(LT)-Simple	Fixed(HT)-Simple	Rigid-Simple	Rigid-Rigid
RS100025 1.000 inch dia. 0.250 inch lead	<i>Non-preloaded</i> Ball (N1/N2)	< 20 (0,14)	< 25 (0,18)	< 35 (0,25)	< 35 (0,25)	< 50 (0,35)
	<i>Preloaded</i> Ball (N3/N4)	< 35 (0,25)	< 40 (0,28)	< 50 (0,35)	< 50 (0,35)	< 65 (0,45)
	<i>Non-preloaded</i> Turcite (N5/N6)	< 30 (0,21)	< 35 (0,25)	< 45 (0,32)	< 45 (0,32)	< 60 (0,42)
	<i>Preloaded</i> Turcite (N7/N8)	< 55 (0,39)	< 60 (0,42)	< 70 (0,49)	< 70 (0,49)	< 85 (0,60)
RS100050 1.000 inch dia. 0.500 inch lead	<i>Non-preloaded</i> Ball (N1/N2)	< 25 (0,18)	< 30 (0,21)	< 50 (0,35)	< 50 (0,35)	< 65 (0,45)
	<i>Preloaded</i> Ball (N3/N4)	< 45 (0,32)	< 50 (0,35)	< 70 (0,49)	< 70 (0,49)	< 80 (0,56)
	<i>Non-preloaded</i> Turcite (N5/N6)	< 40 (0,28)	< 45 (0,32)	< 65 (0,45)	< 65 (0,45)	< 80 (0,56)
	<i>Preloaded</i> Turcite (N7/N8)	< 75 (0,53)	< 80 (0,56)	< 100 (0,70)	< 100 (0,70)	< 115 (0,81)
RS100100 1.000 inch dia. 1.000 inch lead	<i>Non-preloaded</i> Ball (N1/N2)	< 30 (0,21)	< 35 (0,25)	< 55 (0,39)	< 55 (0,39)	< 75 (0,53)
	<i>Preloaded</i> Ball (N3/N4)	< 55 (0,39)	< 60 (0,42)	< 80 (0,56)	< 80 (0,56)	< 100 (0,71)
	<i>Non-preloaded</i> Turcite (N5/N6)	< 45 (0,32)	< 50 (0,35)	< 70 (0,49)	< 70 (0,49)	< 90 (0,64)
	<i>Preloaded</i> Turcite (N7/N8)	< 85 (0,60)	< 90 (0,64)	< 110 (0,79)	< 110 (0,79)	< 130 (0,92)

Support Housing Specifications

Support Housing Life millions of screw revolutions	Support Housing Thrust Load Capacity - (Axial)			
	Simple	Fixed (LT)	Fixed (HT)	Rigid
Static	2,880 (1306)	3,630 (1646)	6,615 (3000)	6,615 (3000)
1	2,880 (1306)	3,630 (1646)	5,240 (2377)	5,240 (2377)
2	2,285 (1036)	2,880 (1306)	4,160 (1887)	4,160 (1887)
10	1,335 (606)	1,685 (764)	2,430 (1102)	2,430 (1102)
50	805 (365)	990 (449)	1,420 (644)	1,420 (644)
100	620 (281)	795 (360)	1,130 (512)	1,130 (512)
500	375 (170)	455 (206)	660 (299)	660 (299)

Thrust force applied in either direction

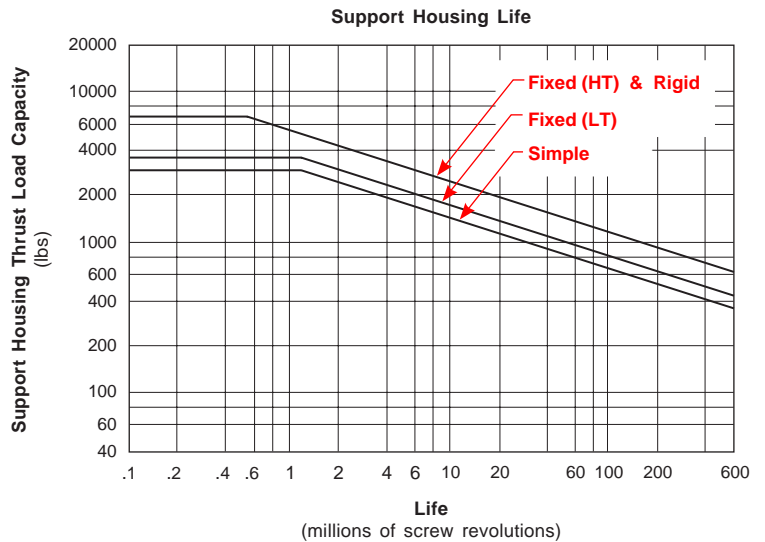
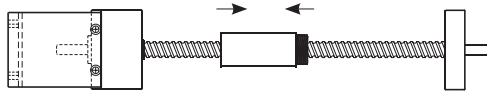

Note: Multiply screw revolutions by the screw lead in order to convert to inches (or mm) traveled by the nut.

Available Configurations

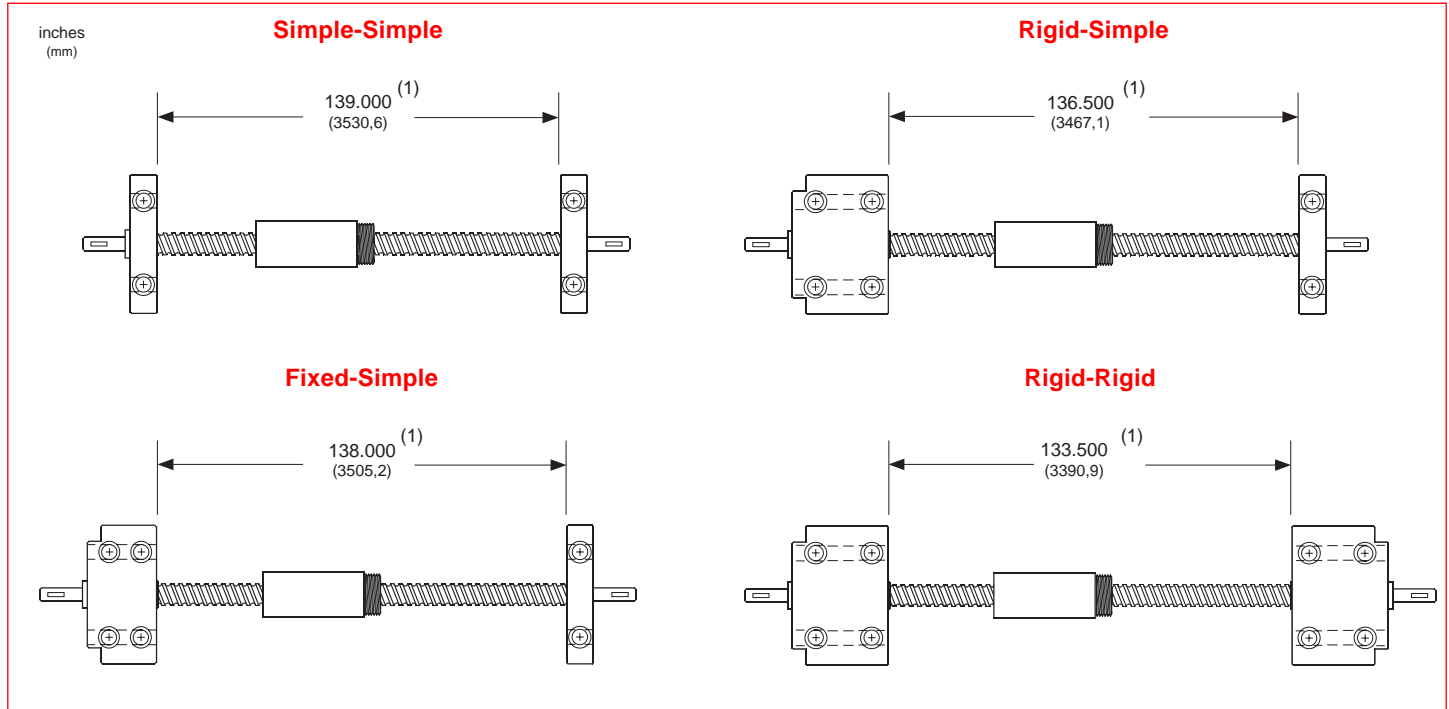

Overall Length Diagram

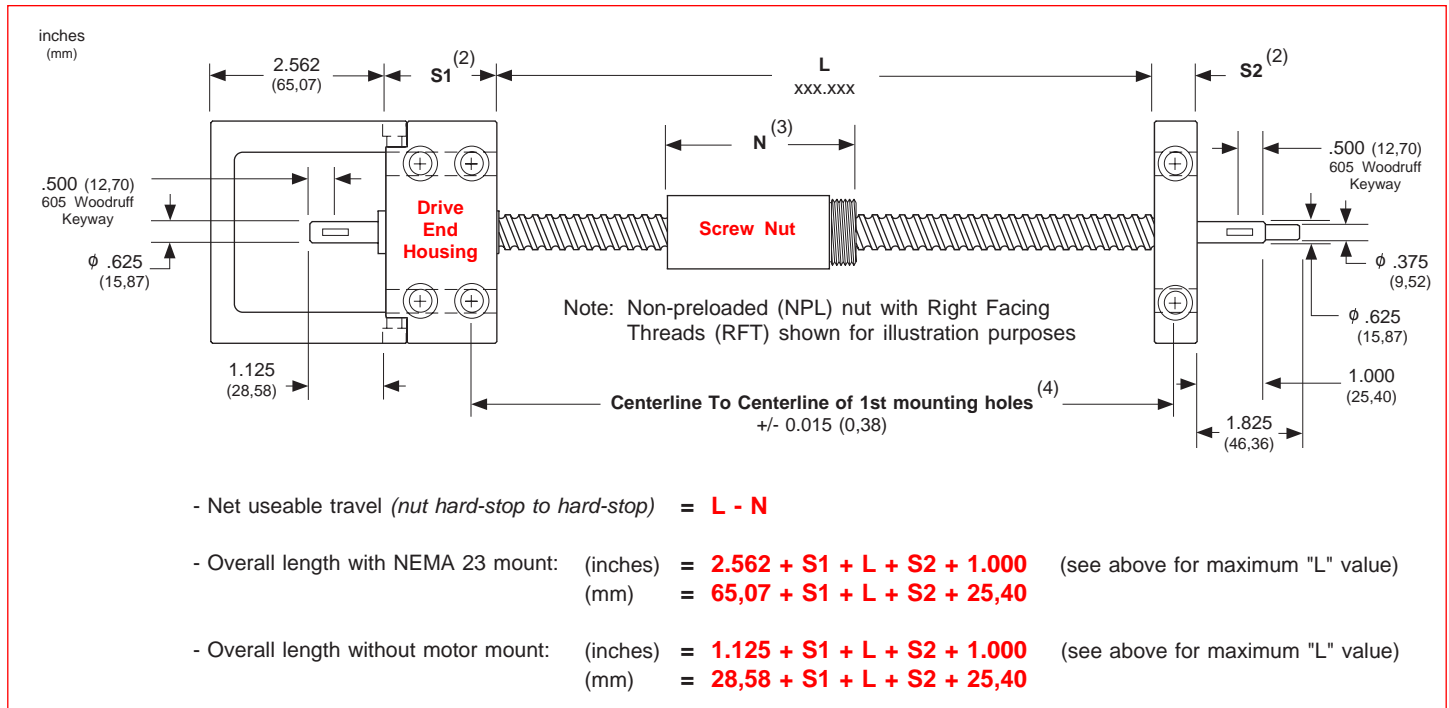

Footnotes:

- (1) Maximum available standard screw thread length for the bearing support housing configuration shown.
- (2) Fixed-simple support configuration shown for reference. See page 53 for length values for simple, fixed, and rigid housings.
- (3) See page 52 for available nut styles. Refer to A1 & A2 values for the nut length. See page 96 for wiper kit lengths.
- (4) Tolerance shown is for base mounted support housings. Tolerance also applies to face mounted support housings.

Performance Charts

Simple-Simple

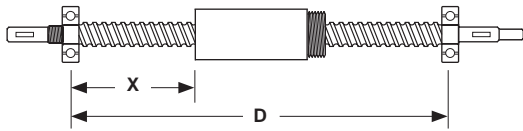

Rigid-Simple

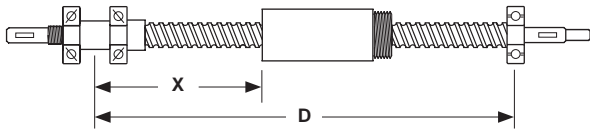

Rigid-Rigid

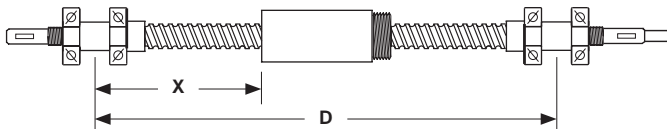

Maximum Compression Load ⁽¹⁾

X inches	(mm)	simple-simple		rigid-simple		rigid-rigid	
		lbs	(kgf)	lbs	(kgf)	lbs	(kgf)
40	(1016)	3430	(1556)	6860	(3112)	13720	(6223)
80	(2032)	855	(388)	1710	(776)	3420	(1551)
120	(3048)	380	(172)	760	(345)	1520	(690)

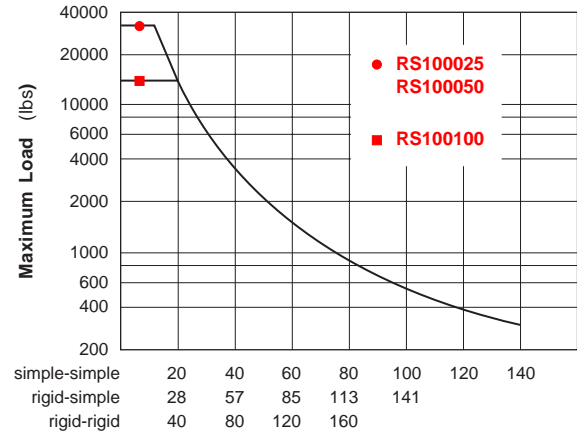

Maximum "X" distance between bearing support and Load (inches)

Maximum Speed ⁽¹⁾

D inches	(mm)	simple-simple	rigid-simple	rigid-rigid
		rpm	rpm	rpm
34	(864)	3000	3000	3000
60	(1524)	970	1425	2160
100	(2540)	345	510	775
140	(3556)	175	260	395

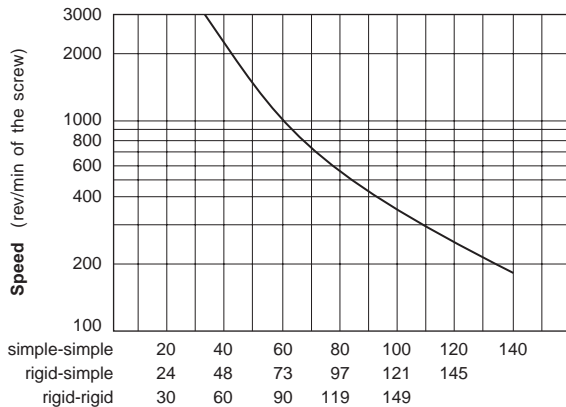

Maximum "D" distance between bearing supports (inches)

Screw Travel Life ⁽²⁾

Life millions of inches (km)	100025		100050		100100		Turcite Nut	
	lbs	(kgf)	lbs	(kgf)	lbs	(kgf)	lbs	(kgf)
1 (25)	3350	(1520)	3950	(1792)	2250	(1020)	195	(88)
2 (50)	2710	(1229)	3200	(1451)	1820	(825)	160	(72)
50 (1270)	990	(449)	1100	(499)	670	(304)	55	(29)
100 (2540)	810	(367)	970	(440)	560	(254)	45	(20)

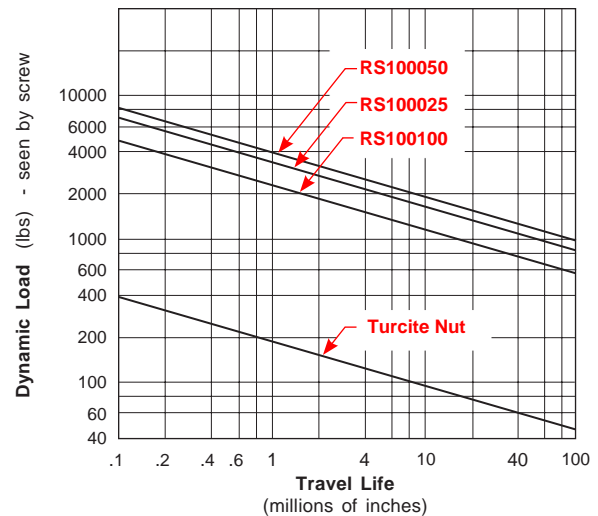

Footnotes:

- Refer to the simple-simple support lengths for fixed-simple configurations. A fixed housing performs like a simple housing for critical speed and compression load specifications. Maximum speeds may not be reached using a Turcite nut due to system friction.
- Multiply life value from chart (or graph) by 0.90 to obtain the life for a preloaded ball nut.

Nut Dimensions

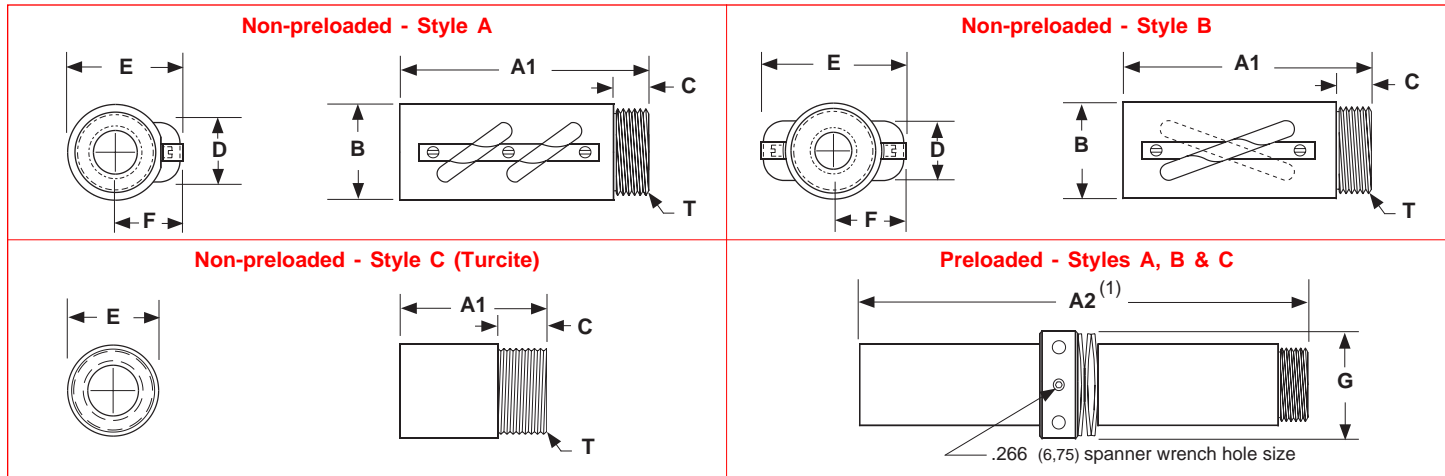

Nut Flange Dimensions

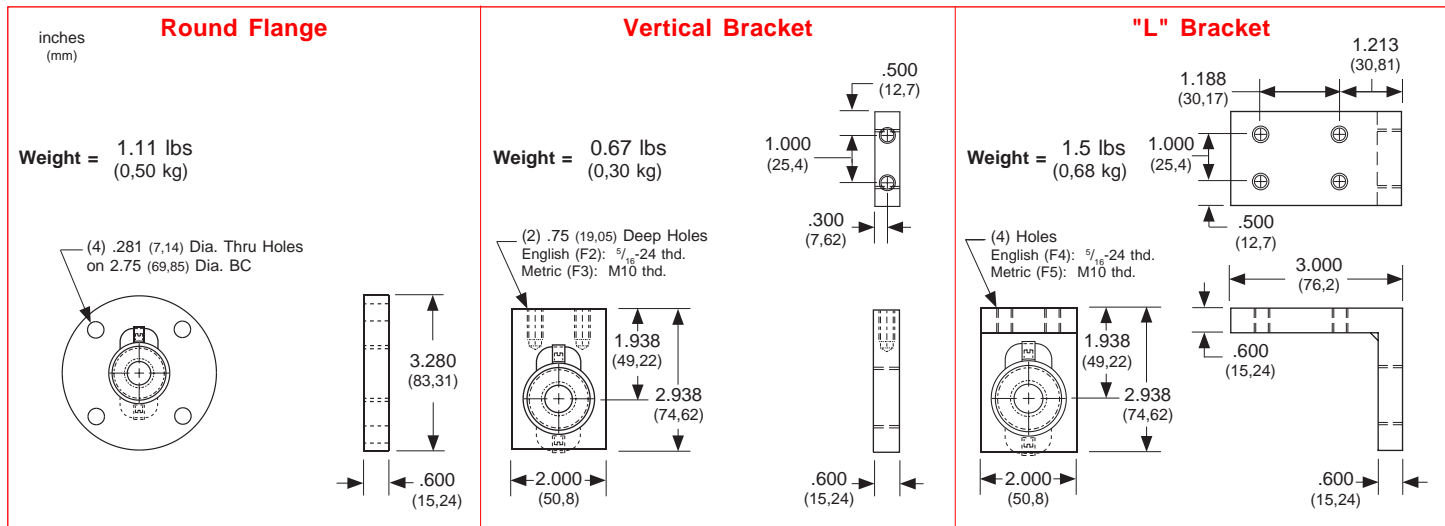

Model Number	Nut Style	Nut Dimensions inches (mm)									Nut Weight lbs (kg)
		A1	A2 ⁽¹⁾	B	C	D	E	F	T - "V" Threads ⁽²⁾	G	
RS100025	A	3.140 (79,76)	6.640 (168,66)	1.692 (42,98)	0.630 (16,00)	1.191 (30,25)	1.882 (47,80)	1.120 (28,45)	1 9/16 - 18 UNEF-2A (39,68 - 18 UNEF-2A)	2.070 (52,57)	1.25 (0,56)
RS100050	B	3.130 (79,50)	6.640 (168,66)	1.692 (42,98)	0.630 (16,00)	1.191 (30,25)	1.882 (47,80)	1.120 (28,45)	1 9/16 - 18 UNEF-2A (39,68 - 18 UNEF-2A)	2.070 (52,57)	1.25 (0,56)
RS100100	B	3.100 (78,74)	6.520 (165,61)	1.692 (42,98)	0.605 (15,37)	1.200 (30,48)	2.172 (55,17)	1.170 (29,72)	1 9/16 - 18 UNEF-2A (39,68 - 18 UNEF-2A)	2.070 (52,57)	1.25 (0,56)
RS100025	C	1.500 (38,10)	3.500 (88,90)	n/a	0.600 (15,24)	n/a	1.750 (44,45)	n/a	1 9/16 - 18 UNEF-2A (39,68 - 18 UNEF-2A)	n/a	0.35 (0,15)
RS100050	C	1.500 (38,10)	3.500 (88,90)	n/a	0.600 (15,24)	n/a	1.750 (44,45)	n/a	1 9/16 - 18 UNEF-2A (39,68 - 18 UNEF-2A)	n/a	0.35 (0,15)
RS100100	C	1.500 (38,10)	3.500 (88,90)	n/a	0.600 (15,24)	n/a	1.750 (44,45)	n/a	1 9/16 - 18 UNEF-2A (39,68 - 18 UNEF-2A)	n/a	0.35 (0,15)

Footnotes:

- (1) This is the length for a preloaded nut. Preloaded nut consists of two (2) non-preloaded nuts with a locking spanner nut, and belville springs.
- (2) All flange threads are internal (Type 2B) to match the external nut threads.
- (3) Weight of the non-preloaded nut. Multiply value by 2.1 to obtain the weight for the preloaded nut assembly.

Support Housing Dimensions

<p>inches (mm)</p> <p>.813 (20,65)</p> <p>2.750 (69,85)</p> <p>(4) .406 (10,31) Dia.Thru Holes</p> <p>(4) 10-32 Dia. x .50 (12,7) Deep on 2.500 (63,5) BC</p> <p>3.625 (92,08)</p> <p>2.625 (66,68)</p> <p>1.813 (46,05)</p> <p>.500 (12,70)</p> <p>2.188 (55,58)</p> <p>4.375 (111,13)</p>	<p>Simple</p> <p>Weight = 2.5 lbs (1,14 kg)</p>	<p>.375 (9,52)</p> <p>(2) .406 (10,3) Dia. Thru Holes, .620 (15,75) Dia. C' Bored x .75 (19,05) Deep</p> <p>Drive End</p> <p>non-Drive End</p> <p>.750 (19,05)</p> <p>.750 (19,05)</p>
<p>.813 (20,65)</p> <p>2.750 (69,85)</p> <p>(4) .406 (10,31) Dia.Thru Holes</p> <p>(4) 10-32 Dia. x .50 (12,7) Deep on 2.500 (63,5) BC</p> <p>3.625 (92,08)</p> <p>2.625 (66,68)</p> <p>1.813 (46,05)</p> <p>.500 (12,70)</p> <p>2.188 (55,58)</p> <p>4.375 (111,13)</p> <p>.375 (9,52)</p>	<p>Fixed</p> <p>Weight = 6.6 lbs (2,99 kg)</p>	<p>1.125 (28,57)</p> <p>.500 (12,70)</p> <p>(4) .406 (10,3) Dia. Thru Holes, .620 (15,75) Dia. C' Bored x .75 (19,05) Deep</p> <p>1.875 (47,63)</p> <p>(2) 10-32 x .44 (11,18) Deep, both sides</p> <p>.875 (22,23)</p> <p>.125 (3,17)</p> <p>2.125 (53,97)</p>
<p>.813 (20,65)</p> <p>2.750 (69,85)</p> <p>(4) .406 (10,31) Dia.Thru Holes</p> <p>(4) 10-32 Dia. x .50 (12,7) Deep on 2.500 (63,5) BC</p> <p>3.625 (92,08)</p> <p>2.625 (66,68)</p> <p>1.813 (46,05)</p> <p>.500 (12,70)</p> <p>2.188 (55,58)</p> <p>4.375 (111,13)</p> <p>.375 (9,52)</p>	<p>Rigid</p> <p>Weight = 11.8 lbs (5,35 kg)</p>	<p>2.625 (66,67)</p> <p>.500 (12,70)</p> <p>(4) .406 (10,3) Dia. Thru Holes, .620 (15,75) Dia. C' Bored x .75 (19,05) Deep</p> <p>1.875 (47,63)</p> <p>(2) 10-32 x .44 (11,18) Deep, both sides</p> <p>.875 (22,23)</p> <p>.125 (3,17)</p> <p>3.625 (92,07)</p>
<p>NEMA 34 Motor Mount</p> <p>Weight = 2.0 lbs (0,91 kg)</p> <p>(4) Holes on 3.875 (98,42) BC Dia. English (M04): #10-24 thd. Metric (M05): M5 thd.</p> <p>2.876 (73,05) Pilot Dia. TYP</p> <p>3.460 (87,88)</p> <p>3.187 (80,95)</p> <p>.313 (7,95)</p> <p>2.062 (52,37)</p> <p>3.375 (85,73)</p> <p>1.688 (42,88)</p> <p>(2) .221 (5,61) Dia.Thru Holes, .344 (8,74) Dia. C' Bored x .200 (5,08) Deep, both sides</p> <p>4.375 (111,13)</p>	<p>NEMA 42 Motor Mount</p> <p>Weight = 3.2 lbs (1,45 kg)</p> <p>(4) Holes on 4.950 (125,73) BC Dia. English (M10): # 1/2-20 thd. Metric (M11): M6 thd.</p> <p>2.189 (55,60) Pilot Dia. TYP</p> <p>3.460 (87,88)</p> <p>0.375 (9,53)</p> <p>3.187 (80,95)</p> <p>.313 (7,95)</p> <p>3.062 (77,77)</p> <p>4.250 (107,95)</p> <p>2.125 (53,98)</p> <p>.313 (7,95)</p> <p>(2) .221 (5,61) Dia.Thru Holes, .344 (8,74) Dia. C' Bored x .200 (5,08) Deep, both sides</p> <p>4.250 (107,95)</p>	